



# MSTM

ISO 9001:2015 Certified

# INSERTS

TURNING | PARTING & GROOVING

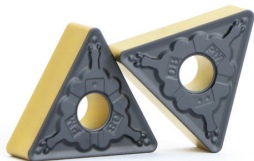

[www.mstm.co.in](http://www.mstm.co.in)



# INDEX

PAGE NO.

---

## TURNING INSERTS

<b>CNMA/CNMG</b>	<b>9-11</b>
<b>DNMA/DNMG</b>	<b>12-13</b>
<b>SNMA/SNMG</b>	<b>14-15</b>
<b>TNMA/TNMG</b>	<b>16-18</b>
<b>VNMG</b>	<b>19-20</b>
<b>WNMA/WNMG</b>	<b>21-23</b>
<b>CCMT/CCGT</b>	<b>24-25</b>
<b>DCMT/DCGT</b>	<b>26-27</b>
<b>SCMT</b>	<b>28</b>
<b>VBMT/VCMT/VBGT</b>	<b>29-30</b>
<b>TCMT</b>	<b>31</b>

## PARTING / GROOVING INSERTS

<b>MSMN/MSJN</b>	<b>34</b>
<b>MSTG</b>	<b>35</b>

# Recommended Grade Table

## Turning Inserts

Grades	Application range					P	M	K	N	S	H				
	05	10	15	20	25	30	35	40	45	Steel	Stainless	Cast iron	Non-ferrous metals	Heat-resistant	Hard materials
<b>CVD Grades</b>															
MSC-4115A	●	●	●												
MSC-4125A			●	●	●						○				
MSC-4130A					●	●	●	●			○				
MSK-3110A	●	●	●	●							●				
MSK-3125B			●	●	●						●				
<b>PVD Grades</b>															
MSP-1210A	●	●	●								●				
MSP-1225A			●	●	●						●				
MSP-1235A					●	●	●	●			●				
MSP-2125A			●	●	●						●			●	
MSP-2210A	●	●	●								●			●	
MSP-2230A			●	●	●						●			○	
MSP-2235A					●	●	●	●			●				
MSP-4105A	●	●	●								●				○
MSP-4210A		●	●	●							○				
MSP-4230A			●	●	●						●				
MSP-4235A					●	●	●	●			●				
MSP-6210A	●	●	●								○	●		●	●
MSP-6230A		●	●	●							○	●		●	●
MSP-6235A					●	●	●	●			○	●		●	●
MSP-6220B		●	●	●							○	●		●	●

# Recommended Grade Table

## Turning Inserts

Grades	Application range						P	M	K	N	S	H				
	05	10	15	20	25	30	35	40	45	Steel	Stainless	Cast iron	Non-ferrous metals	Heat-resistant	Hard materials	
<b>Cermet Grade</b> <i>MS-TC30B</i>	[Blue bar from 05 to 25]						●		○							○

# Recommended Grade Table

## Parting & Grooving

Grades	Application range						P	M	K	N	S	H				
	05	10	15	20	25	30	35	40	45	Steel	Stainless	Cast iron	Non-ferrous metals	Heat-resistant	Hard materials	
<b>CVD Grades</b> <i>MSC-7125A</i>	[Blue bar from 05 to 25]						●	●	●							
<b>PVD Grades</b> <i>MSP-7125A</i>			[Blue bar from 15 to 35]				●	●	●							
<i>MSP-7125B</i>			[Blue bar from 15 to 35]				●	●	●							
<i>MSP-8125B</i>			[Blue bar from 15 to 35]				●	●	○							



**TURNING  
INSERTS**

# Insert Nomenclature - ISO

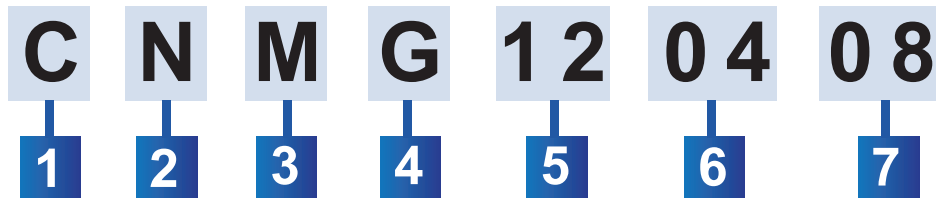

## 1 - Shape

Symbol	Shape	
H	Hexagonal	
O	Octagonal	
P	Pentagonal	
S	Square	
T	Triangular	
C	Rhombic 80°	
D	Rhombic 55°	
V	Rhombic 35°	
W	Trigon	
L	Rectangular	
K	Parallelogram 55°	
R	Round	

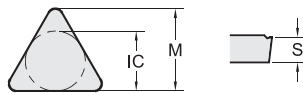

## 3 - Tolerance Class

Symbol	Inner Circle IC (mm)	Nose Height M (mm)	Thickness S (mm)
C	± 0.025	± 0.013	± 0.025
E	± 0.025	± 0.025	± 0.025
G	± 0.025	± 0.025	± 0.13
H	± 0.013	± 0.013	± 0.025
K*	± 0.05-0.15*	± 0.013	± 0.025
M*	± 0.05-0.15*	± 0.08-0.2*	± 0.13
U*	± 0.08-0.25*	± 0.13-0.38*	± 0.13

\*Tolerance is different by insert IC size. Please see ISO 1832

## 4 - Clamping & Chipbreaker

Symbol	Clamping	Chipbreaker	Figure
N	No clamping hole	X	
R		One Face	
A	Cylindrical clamping hole	X	
M		One Face	
G		Both Faces	
W	Screw Hole	X	
T		One Face	
U		Both Faces	
X	Special		

## 2 - Relief Angle (AN)

Symbol	Relief Angle (AN)	
N	No Relief Angle	
B	Relief 5°	
C	Relief 7°	
P	Relief 11°	
D	Relief 15°	
E	Relief 20°	
F	Relief 25°	
O	Special	

## 5 - Insert Size

Metric							Inner Circle IC (mm)	Inch
S	T	C	D	V	W	R		
06	11	06	07	11			6.35	2
07							7.94	2.5
09	16	09	11	16	06	09 (00)	9.525	3
12	22	12	15	22	08	12 (00)	12.7	4
15		16					15.875	5
19		19					19.05	6
25		25					25.4	8
						06 (M0)	6	
						08 (M0)	8	
						10 (M0)	10	
						12 (M0)	12	
						16 (M0)	16	



## 6 - Insert Thickness (S)

Metric	Thickness - S (mm)	Inch
T1	1.98	1.2
02	2.38	1.5
03	3.18	2
T3	3.97	2.5
04	4.76	3
05	5.56	3.5
06	6.35	4
07	7.94	5
09	9.525	6

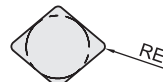

## 7 - Corner Radius (RE)

Metric	Corner Radius - RE (mm)	Inch
01	0.1	0
02	0.2	0.5
04	0.4	1
08	0.8	2
12	1.2	3
16	1.6	4
20	2.0	5
24	2.4	6

# TURNING INSERTS

## Characteristics of Chip-breakers

### PM4 Positive Inserts

A chip-breaker for cutting carbon steel, alloy steel, soft steel, stainless steel, and cast iron. The combination of a flat edge and a large front angle ensures edge strength and cutting sharpness.

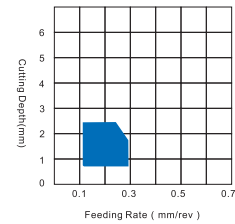
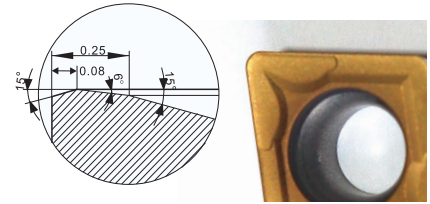

### PM4 Negative Inserts

Preferred chip-breakers for semi-finishing machining of steel ensure efficient and stable processing. Universal chip-breakers with a wide chip-breaking effect and high versatility are designed near the tip of the tool, featuring a distinctive shape bulge and large front angle. These chip-breakers maintain sharp cutting performance and low cutting force.

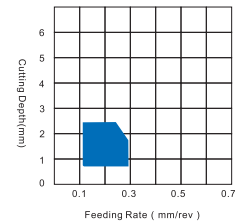
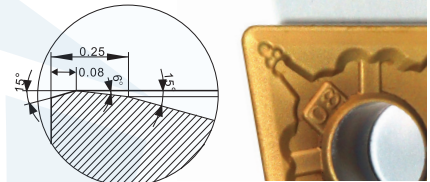

### PF Positive Inserts

Chip-breaker for Precision Processing with Front Angle Finishing:

- Design of parallel cutting edges
- Special design of 3D chip-breakers with a double front angle
- Small cutting force and wide chip-breaking
- Large front angle design and deep chip chute to enhance edge sharpness
- Raised chip-breakers corresponding to different levels of cutting depth
- Extensive application field

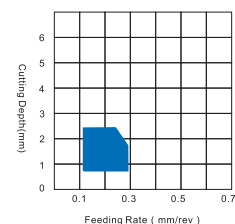
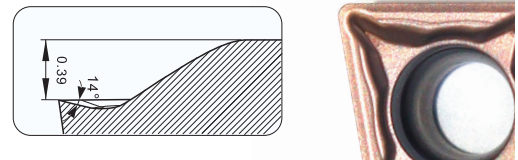

# TURNING INSERTS

## Characteristics of Chip-breakers

### SM3 Positive Inserts

Medium cutting chip-breakers use a large chip-holding groove. They reduce cutting resistance even at large depths of cut, and reduce high-frequency vibration and cutting blockage.

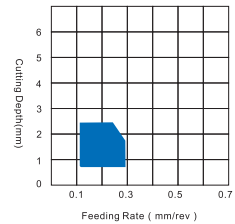
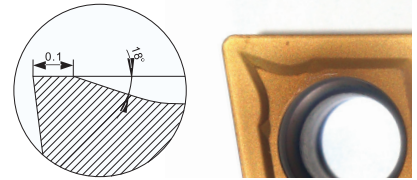

### SM3 Negative Inserts

Medium Cutting for Stainless Steel, Soft Steel, and Hard Cutting Materials

Use preferred recommended chip-breakers:

- M-class double-sided chip-breakers
- Sharp cutting edges
- High cutting sharpness
- Highly versatile chip-breaker shape

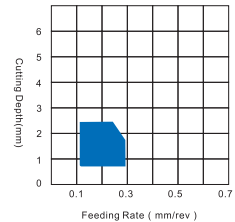
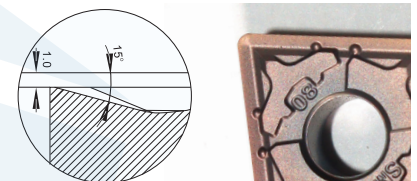

### KR5 Positive Inserts

**Flat Chip-Breakers:**

Chip-breakers for cutting brittle and hard materials, with high structural strength and a good fit to the tool holder. More suitable for unstable turning of cast iron.

**Universal Chip-Breakers:**

Universal chip-breaker type, double-sided chip-breakers, especially suitable for machining K-type materials.

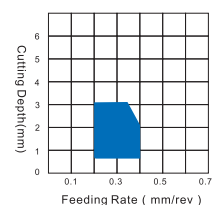
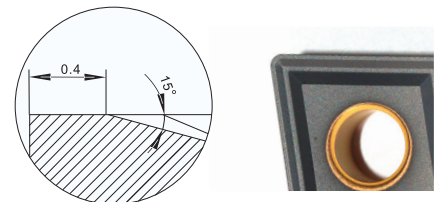



# TURNING INSERTS

## Characteristics of Chip-breakers

### MM Geometry Inserts

Positive geometry designed for finishing to semi-rough machining of steel, cast iron, and potentially superalloys, allowing for continuous and moderately interrupted cuts.

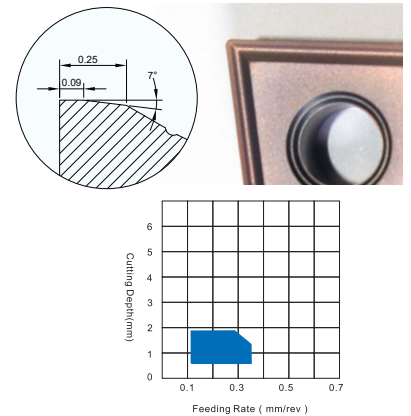

### TM Geometry Inserts

Positive geometry designed for medium machining of stainless steels, super alloys, steel, and cast irons, as well as potentially non-ferrous and hard materials. It is also suitable for machining thin walls, allowing for both continuous and interrupted cuts.

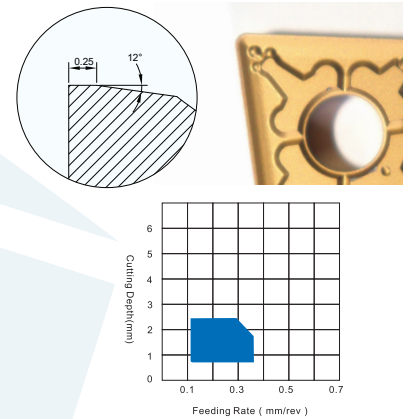

### MR Geometry Inserts

Positive design for medium to rough machining of stainless steels, soft steels, and super alloys, allowing for continuous cuts.

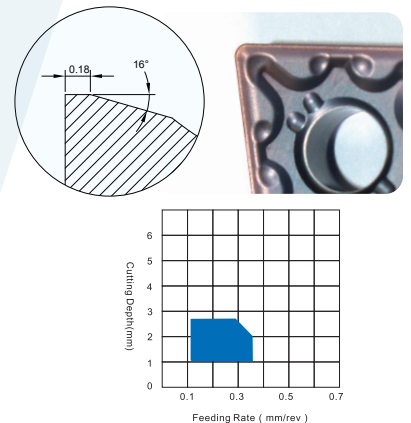

### NM Geometry Inserts

Highly positive design for medium machining of stainless steels, steel, potentially cast irons, non-ferrous materials, and superalloys, enabling continuous cuts.

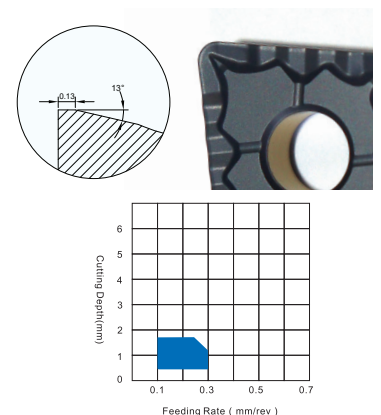

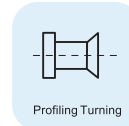

## CNMA/CNMG

$\frac{C}{L}$	IC [mm]	D1 [mm]	L [mm]	S [mm]
1204	12.7	5.16	12.9	4.76
1906	19.05	7.94	19.3	6.35

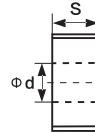
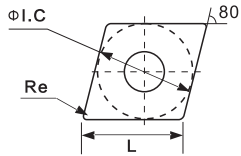

Type	Grade	P	M	K	N	S	H
<b>CNMA 120408</b> <b>CNMA 120412</b>	MSC-4115A						
	MSC-4125A						
	MSC-4130A						
	MSK-3110A			●			
	MSK-3125B						
	MSP-1210A						
	MSP-1225A						
	MSP-1235A						
	MSP-2125A						
	MSP-2210A						
	MSP-2230A						
	MSP-2235A						
	MSP-4105A						
	MSP-4210A						
	MSP-4230A						
	MSP-4235A						
	MSP-6210A						
	MSP-6230A						
	MSP-6235A						
	MSP-6220B						
<b>CNMG 120404-KR5</b> <b>CNMG 120408-KR5</b> <b>CNMG 120412-KR5</b>	MSC-4115A						
	MSC-4125A						
	MSC-4130A						
	MSK-3110A			●			
	MSK-3125B			●			
	MSP-1210A						
	MSP-1225A	●	○	●			
	MSP-1235A	●	○	●			
	MSP-2125A						
	MSP-2210A						
	MSP-2230A		●			●	
	MSP-2235A						
	MSP-4105A						
	MSP-4210A						
	MSP-4230A	●	○	●			
	MSP-4235A	●	○	●			
	MSP-6210A						
	MSP-6230A		●			●	
	MSP-6235A						
	MSP-6220B						

● Recommended ○ Good

Type	Grade	P	M	K	N	S	H
<b>CNMG 120404-MM</b>	MSC-4115A						
	MSC-4125A						
	MSC-4130A						
	MSK-3110A						
	MSK-3125B						
	MSP-1210A						
	MSP-1225A	●	○	●			
	MSP-1235A						
	MSP-2125A	●	●			●	
	MSP-2210A		●			●	
	MSP-2230A		●			●	
	MSP-2235A						
	MSP-4105A						
	MSP-4210A						
	MSP-4230A	●	○	●			
	MSP-4235A						
	MSP-6210A						
	MSP-6230A		●			●	
	MSP-6235A						
	MSP-6220B						
<b>CNMG 120412-MR</b> <b>CNMG 120408-MR</b>	MSC-4115A						
	MSC-4125A						
	MSC-4130A						
	MSK-3110A						
	MSK-3125B						
	MSP-1210A						
	MSP-1225A	●	○	●			
	MSP-1235A						
	MSP-2125A	●	●			●	
	MSP-2210A		●			●	
	MSP-2230A						
	MSP-2235A						
	MSP-4105A						
	MSP-4210A	●	●	●			
	MSP-4230A	●	○	●			
	MSP-4235A						
	MSP-6210A						
	MSP-6230A						
	MSP-6235A						
	MSP-6220B						

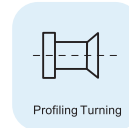

● Recommended ○ Good



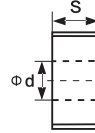
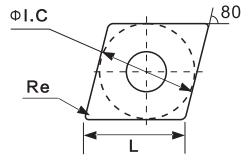

## CNMA/CNMG

	IC [mm]	D1 [mm]	L [mm]	S [mm]
1204	12.7	5.16	12.9	4.76
1906	19.05	7.94	19.3	6.35



Type	Grade	P	M	K	N	S	H
<b>CNMG 120408-NM</b> <b>CNMG 120412-NM</b> 	MSC-4115A						
	MSC-4125A	●	●				
	MSC-4130A	●					
	MSK-3110A						
	MSK-3125B						
	MSP-1210A						
	MSP-1225A						
	MSP-1235A						
	MSP-2125A						
	MSP-2210A						
	MSP-2230A						
	MSP-2235A						
	MSP-4105A						
	MSP-4210A						
	MSP-4230A						
	MSP-4235A						
	MSP-6210A						
	MSP-6230A						
	MSP-6235A						
	MSP-6220B						
<b>CNMG 120404-PM4</b> <b>CNMG 120408-PM4</b> <b>CNMG 120412-PM4</b> 	MSC-4115A						
	MSC-4125A	●	●				
	MSC-4130A	●					
	MSK-3110A						
	MSK-3125B						
	MSP-1210A						
	MSP-1225A						
	MSP-1235A						
	MSP-2125A						
	MSP-2210A						
	MSP-2230A		●			●	
	MSP-2235A						
	MSP-4105A						
	MSP-4210A						
	MSP-4230A	●	○	●			
	MSP-4235A						
	MSP-6210A						
	MSP-6230A		●			●	
	MSP-6235A						
	MSP-6220B						

● Recommended ○ Good

Type	Grade	P	M	K	N	S	H
<b>CNMG 190608-PR8</b> <b>CNMG 190612-PR8</b> <b>CNMG 190616-PR8</b> 	MSC-4115A						
	MSC-4125A	●	●				
	MSC-4130A	●					
	MSK-3110A						
	MSK-3125B						
	MSP-1210A						
	MSP-1225A						
	MSP-1235A						
	MSP-2125A						
	MSP-2210A						
	MSP-2230A						
	MSP-2235A						
	MSP-4105A						
	MSP-4210A						
	MSP-4230A						
	MSP-4235A						
	MSP-6210A						
	MSP-6230A						
	MSP-6235A						
	MSP-6220B						
<b>CNMG 120404-SM3</b> <b>CNMG 120408-SM3</b> 	MSC-4115A						
	MSC-4125A						
	MSC-4130A						
	MSK-3110A						
	MSK-3125B						
	MSP-1210A						
	MSP-1225A	●	○	●			
	MSP-1235A						
	MSP-2125A	●	●			●	
	MSP-2210A		●			●	
	MSP-2230A		●			●	
	MSP-2235A						
	MSP-4105A						
	MSP-4210A	●	○	●			
	MSP-4230A	●	○	●			
	MSP-4235A						
	MSP-6210A						
	MSP-6230A		●			●	
	MSP-6235A						
	MSP-6220B						

● Recommended ○ Good

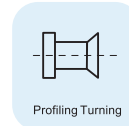

## CNMA/CNMG

	IC [mm]	D1 [mm]	L [mm]	S [mm]
1204	12.7	5.16	12.9	4.76
1906	19.05	7.94	19.3	6.35

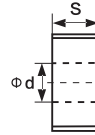
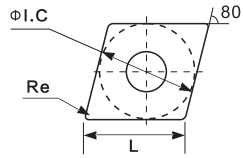

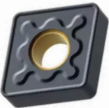

Type	Grade	P	M	K	N	S	H
<b>CNMG 120404-TM</b> <b>CNMG 120408-TM</b> <b>CNMG 120412-TM</b> 	MSC-4115A						
	MSC-4125A	●	●				
	MSC-4130A						
	MSK-3110A						
	MSK-3125B						
	MSP-1210A						
	MSP-1225A						
	MSP-1235A						
	MSP-2125A						
	MSP-2210A						
	MSP-2230A		●			●	
	MSP-2235A						
	MSP-4105A						
	MSP-4210A						
	MSP-4230A	●	○	●			
	MSP-4235A						
	MSP-6210A						
	MSP-6230A		●			●	
	MSP-6235A						
	MSP-6220B						
<b>CNMG 120408-KH</b> <b>CNMG 120412-KH</b> 	MSC-4115A						
	MSC-4125A						
	MSC-4130A						
	MSK-3110A						
	MSK-3125B			●			
	MSP-1210A						
	MSP-1225A						
	MSP-1235A						
	MSP-2125A						
	MSP-2210A						
	MSP-2230A						
	MSP-2235A						
	MSP-4105A						
	MSP-4210A						
	MSP-4230A						
	MSP-4235A						
MSP-6210A							
MSP-6230A							
MSP-6235A							
MSP-6220B							

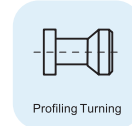
● Recommended ○ Good



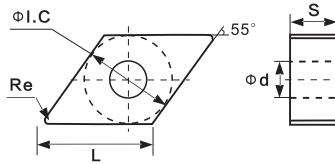

## DNMA/DNMG

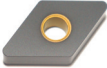
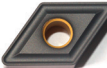

	IC [mm]	D1 [mm]	L [mm]	S [mm]
1504	12.700	5.16	15.50	4.76
1506	12.700	5.16	15.50	6.35

Type	Grade	P	M	K	N	S	H
<b>DNMA 150608</b> <b>DNMA 150612</b> 	MSC-4115A						
	MSC-4125A						
	MSC-4130A						
	MSK-3110A			●			
	MSK-3125B						
	MSP-1210A						
	MSP-1225A						
	MSP-1235A						
	MSP-2125A						
	MSP-2210A						
	MSP-2230A						
	MSP-2235A						
	MSP-4105A						
	MSP-4210A						
	MSP-4230A						
	MSP-4235A						
	MSP-6210A						
	MSP-6230A						
	MSP-6235A						
	MSP-6220B						
<b>DNMG 150608-KR5</b> <b>DNMG 150612-KR5</b> 	MSC-4115A						
	MSC-4125A						
	MSC-4130A						
	MSK-3110A			●			
	MSK-3125B						
	MSP-1210A						
	MSP-1225A						
	MSP-1235A	●	○	●			
	MSP-2125A						
	MSP-2210A						
	MSP-2230A						
	MSP-2235A						
	MSP-4105A						
	MSP-4210A						
	MSP-4230A						
	MSP-4235A	●	○	●			
	MSP-6210A						
	MSP-6230A						
	MSP-6235A						
	MSP-6220B						

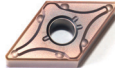
● Recommended ○ Good

Type	Grade	P	M	K	N	S	H
<b>DNMG 150608-MR</b> 	MSC-4115A						
	MSC-4125A						
	MSC-4130A						
	MSK-3110A						
	MSK-3125B						
	MSP-1210A						
	MSP-1225A	●	○	●			
	MSP-1235A						
	MSP-2125A	●	●			●	
	MSP-2210A						
	MSP-2230A		●			●	
	MSP-2235A						
	MSP-4105A						
	MSP-4210A						
	MSP-4230A	●	○	●			
	MSP-4235A						
	MSP-6210A						
	MSP-6230A		●			●	
	MSP-6235A						
	MSP-6220B						
<b>DNMG 150608-PM4</b> <b>DNMG 150612-PM4</b> <b>DNMG 150408-PM4</b> <b>DNMG 150412-PM4</b> 	MSC-4115A						
	MSC-4125A						
	MSC-4130A	●					
	MSK-3110A						
	MSK-3125B						
	MSP-1210A						
	MSP-1225A	●	○	●			
	MSP-1235A						
	MSP-2125A						
	MSP-2210A						
	MSP-2230A		●			●	
	MSP-2235A						
	MSP-4105A						
	MSP-4210A						
	MSP-4230A	●	○	●			
	MSP-4235A						
	MSP-6210A						
	MSP-6230A						
	MSP-6235A						
	MSP-6220B						

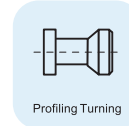

● Recommended ○ Good

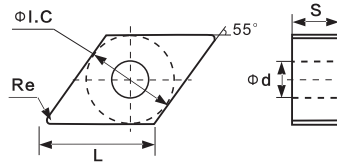

## DNMA/DNMG

	IC [mm]	D1 [mm]	L [mm]	S [mm]
1504	12.700	5.16	15.50	4.76
1506	12.700	5.16	15.50	6.35

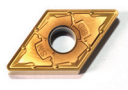

Type	Grade	P	M	K	N	S	H
 <b>DNMG 150404-SM3</b> <b>DNMG 150408-SM3</b>	MSC-4115A						
	MSC-4125A						
	MSC-4130A						
	MSK-3110A						
	MSK-3125B						
	MSP-1210A						
	MSP-1225A	●	○	●			
	MSP-1235A						
	MSP-2125A	●	●			●	
	MSP-2210A		●			●	
	MSP-2230A		●			●	
	MSP-2235A						
	MSP-4105A						
	MSP-4210A	●	○	●			
	MSP-4230A	●	○	●			
	MSP-4235A						
	MSP-6210A						
	MSP-6230A		●			●	
	MSP-6235A						
	MSP-6220B						
 <b>DNMG 150404-TM</b> <b>DNMG 150408-TM</b> <b>DNMG 150412-TM</b> <b>DNMG 150608-TM</b> <b>DNMG 150612-TM</b>	MSC-4115A						
	MSC-4125A	●	●				
	MSC-4130A	●					
	MSK-3110A						
	MSK-3125B						
	MSP-1210A						
	MSP-1225A						
	MSP-1235A						
	MSP-2125A						
	MSP-2210A						
	MSP-2230A						
	MSP-2235A						
	MSP-4105A						
	MSP-4210A						
	MSP-4230A						
	MSP-4235A						
	MSP-6210A						
	MSP-6230A						
	MSP-6235A						
	MSP-6220B						

● Recommended ○ Good

## SNMA/SNMG

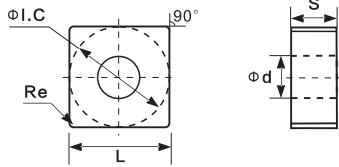
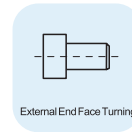

s	IC [mm]	D1 [mm]	L [mm]	S [mm]
1204	12.700	5.16	12.70	4.76
1906	19.050	7.94	19.05	6.35

Type	Grade	P	M	K	N	S	H
<b>SNMA 120408</b> <b>SNMA 120412</b>	MSC-4115A						
	MSC-4125A						
	MSC-4130A						
	MSK-3110A			●			
	MSK-3125B						
	MSP-1210A						
	MSP-1225A						
	MSP-1235A						
	MSP-2125A						
	MSP-2210A						
	MSP-2230A						
	MSP-2235A						
	MSP-4105A						
	MSP-4210A						
	MSP-4230A						
	MSP-4235A						
	MSP-6210A						
	MSP-6230A						
	MSP-6235A						
	MSP-6220B						
<b>SNMG 120408-KR5</b> <b>SNMG 120412-KR5</b>	MSC-4115A						
	MSC-4125A						
	MSC-4130A						
	MSK-3110A			●			
	MSK-3125B						
	MSP-1210A						
	MSP-1225A	●	○	●			
	MSP-1235A	●	○	●			
	MSP-2125A						
	MSP-2210A						
	MSP-2230A		●			●	
	MSP-2235A						
	MSP-4105A						
	MSP-4210A	●	○	●			
	MSP-4230A	●	○	●			
	MSP-4235A	●	○	●			
	MSP-6210A						
	MSP-6230A		●			●	
	MSP-6235A						
	MSP-6220B						



● Recommended ○ Good

Type	Grade	P	M	K	N	S	H
<b>SNMG 120404-MM</b> <b>SNMG 120408-MM</b>	MSC-4115A						
	MSC-4125A						
	MSC-4130A						
	MSK-3110A						
	MSK-3125B	●	●			●	
	MSP-1210A						
	MSP-1225A	●	○	●			
	MSP-1235A						
	MSP-2125A	●	●			●	
	MSP-2210A		●			●	
	MSP-2230A		●			●	
	MSP-2235A						
	MSP-4105A						
	MSP-4210A						
	MSP-4230A	●	○	●			
	MSP-4235A						
	MSP-6210A						
	MSP-6230A		●			●	
	MSP-6235A						
	MSP-6220B						
<b>SNMG 120404-MR</b> <b>SNMG 120408-MR</b> <b>SNMG 120412-MR</b>	MSC-4115A						
	MSC-4125A						
	MSC-4130A						
	MSK-3110A						
	MSK-3125B						
	MSP-1210A						
	MSP-1225A	●	○	●			
	MSP-1235A						
	MSP-2125A	●	●			●	
	MSP-2210A						
	MSP-2230A		●			●	
	MSP-2235A						
	MSP-4105A						
	MSP-4210A						
	MSP-4230A	●	○	●			
	MSP-4235A						
	MSP-6210A						
	MSP-6230A						
	MSP-6235A						
	MSP-6220B						



● Recommended ○ Good

## SNMA/SNMG

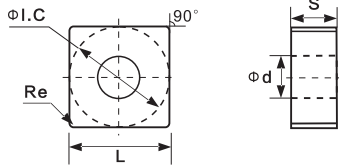
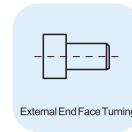

s	IC [mm]	D1 [mm]	L [mm]	S [mm]
1204	12.700	5.16	12.70	4.76
1906	19.050	7.94	19.05	6.35

Type	Grade	P	M	K	N	S	H
<b>SNMG 120404-PM4</b> <b>SNMG 120408-PM4</b>	MSC-4115A						
	MSC-4125A						
	MSC-4130A	●					
	MSK-3110A						
	MSK-3125B						
	MSP-1210A						
	MSP-1225A	●	○	●			
	MSP-1235A						
	MSP-2125A						
	MSP-2210A						
	MSP-2230A		●			●	
	MSP-2235A						
	MSP-4105A						
	MSP-4210A						
	MSP-4230A	●	○	●			
	MSP-4235A						
	MSP-6210A						
	MSP-6230A						
MSP-6235A							
MSP-6220B							
<b>SNMG 190608-PR8</b> <b>SNMG 190612-PR8</b> <b>SNMG 190616-PR8</b>	MSC-4115A						
	MSC-4125A	●	●				
	MSC-4130A	●					
	MSK-3110A						
	MSK-3125B						
	MSP-1210A						
	MSP-1225A						
	MSP-1235A						
	MSP-2125A						
	MSP-2210A						
	MSP-2230A						
	MSP-2235A						
	MSP-4105A						
	MSP-4210A						
	MSP-4230A						
	MSP-4235A						
	MSP-6210A						
	MSP-6230A						
MSP-6235A							
MSP-6220B							

● Recommended ○ Good

Type	Grade	P	M	K	N	S	H
<b>SNMG 120404-SM3</b> <b>SNMG 120408-SM3</b>	MSC-4115A						
	MSC-4125A						
	MSC-4130A						
	MSK-3110A						
	MSK-3125B						
	MSP-1210A						
	MSP-1225A	●	○	●			
	MSP-1235A						
	MSP-2125A	●	○			●	
	MSP-2210A						
	MSP-2230A		●			●	
	MSP-2235A						
	MSP-4105A						
	MSP-4210A						
	MSP-4230A	●	○	●			
	MSP-4235A						
	MSP-6210A						
	MSP-6230A						
MSP-6235A							
MSP-6220B							
<b>SNMG 120404-TM</b> <b>SNMG 120408-TM</b>	MSC-4115A						
	MSC-4125A	●	●				
	MSC-4130A						
	MSK-3110A						
	MSK-3125B						
	MSP-1210A						
	MSP-1225A						
	MSP-1235A						
	MSP-2125A						
	MSP-2210A						
	MSP-2230A						
	MSP-2235A						
	MSP-4105A						
	MSP-4210A						
	MSP-4230A						
	MSP-4235A						
	MSP-6210A						
	MSP-6230A						
MSP-6235A							
MSP-6220B							

● Recommended ○ Good



## TNMA/TNMG

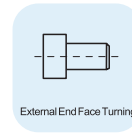

	IC [mm]	D1 [mm]	L [mm]	S [mm]
16	9.525	3.81	16.50	4.76

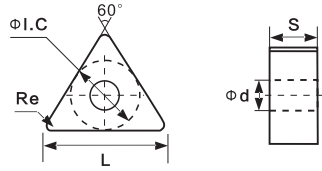

Type	Grade	P	M	K	N	S	H
<b>TNMA 160408</b> <b>TNMA 160412</b>	MSC-4115A						
	MSC-4125A						
	MSC-4130A						
	MSK-3110A			●			
	MSK-3125B						
	MSP-1210A						
	MSP-1225A						
	MSP-1235A						
	MSP-2125A						
	MSP-2210A						
	MSP-2230A						
	MSP-2235A						
	MSP-4105A						
	MSP-4210A						
	MSP-4230A						
	MSP-4235A						
	MSP-6210A						
	MSP-6230A						
	MSP-6235A						
	MSP-6220B						
<b>TNMG 160404-KR5</b> <b>TNMG 160408-KR5</b> <b>TNMG 160412-KR5</b>	MSC-4115A						
	MSC-4125A						
	MSC-4130A						
	MSK-3110A			●			
	MSK-3125B			●			
	MSP-1210A						
	MSP-1225A	●	○	●			
	MSP-1235A	●	○	●			
	MSP-2125A						
	MSP-2210A						
	MSP-2230A		●			●	
	MSP-2235A						
	MSP-4105A		●			●	
	MSP-4210A	●	○	●			
	MSP-4230A	●	○	●			
	MSP-4235A	●	○	●			
	MSP-6210A						
	MSP-6230A		●			●	
	MSP-6235A						
	MSP-6220B						

● Recommended ○ Good

Type	Grade	P	M	K	N	S	H
<b>TNMG 160404-MM</b> <b>TNMG 160408-MM</b>	MSC-4115A						
	MSC-4125A						
	MSC-4130A						
	MSK-3110A						
	MSK-3125B						
	MSP-1210A						
	MSP-1225A	●	○	●			
	MSP-1235A						
	MSP-2125A	●	●			●	
	MSP-2210A		●			●	
	MSP-2230A		●			●	
	MSP-2235A						
	MSP-4105A						
	MSP-4210A	●	○	●			
	MSP-4230A	●	○	●			
	MSP-4235A						
	MSP-6210A						
	MSP-6230A		●			●	
	MSP-6235A						
	MSP-6220B						
<b>TNMG 160408-MR</b> <b>TNMG 160412-MR</b>	MSC-4115A						
	MSC-4125A						
	MSC-4130A						
	MSK-3110A						
	MSK-3125B						
	MSP-1210A						
	MSP-1225A	●	○	●			
	MSP-1235A						
	MSP-2125A	●	●			●	
	MSP-2210A						
	MSP-2230A		●			●	
	MSP-2235A						
	MSP-4105A		●			●	
	MSP-4210A	●	○	●			
	MSP-4230A	●	○	●			
	MSP-4235A						
	MSP-6210A						
	MSP-6230A						
	MSP-6235A						
	MSP-6220B						

● Recommended ○ Good

## TNMA/TNMG

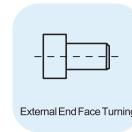

IC [mm]	D1 [mm]	L [mm]	S [mm]	
16	9.525	3.81	16.50	4.76

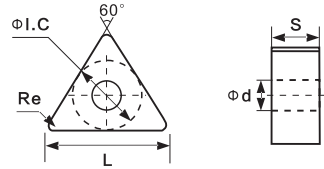

Type	Grade	P	M	K	N	S	H
<b>TNMG 160408-NM</b> <b>TNMG 160412-NM</b>	MSC-4115A	●					
	MSC-4125A	●	○	●			
	MSC-4130A	●					
	MSK-3110A						
	MSK-3125B						
	MSP-1210A						
	MSP-1225A						
	MSP-1235A						
	MSP-2125A						
	MSP-2210A						
	MSP-2230A						
	MSP-2235A						
	MSP-4105A						
	MSP-4210A						
	MSP-4230A						
	MSP-4235A						
	MSP-6210A						
	MSP-6230A						
	MSP-6235A						
	MSP-6220B						
<b>TNMG 160404-PM4</b> <b>TNMG 160408-PM4</b> <b>TNMG 160412-PM4</b>	MSC-4115A						
	MSC-4125A						
	MSC-4130A	●					
	MSK-3110A						
	MSK-3125B						
	MSP-1210A						
	MSP-1225A	●	○	●			
	MSP-1235A						
	MSP-2125A						
	MSP-2210A						
	MSP-2230A		●			●	
	MSP-2235A						
	MSP-4105A						
	MSP-4210A						
	MSP-4230A	●	○	●			
	MSP-4235A						
	MSP-6210A						
	MSP-6230A						
	MSP-6235A						
	MSP-6220B						

● Recommended ○ Good

Type	Grade	P	M	K	N	S	H
<b>TNMG 160404L-PN</b> <b>TNMG 160404R-PN</b> <b>TNMG 160408L-PN</b> <b>TNMG 160408R-PN</b>	MSC-4115A						
	MSC-4125A	●	●				
	MSC-4130A						
	MSK-3110A						
	MSK-3125B						
	MSP-1210A						
	MSP-1225A						
	MSP-1235A						
	MSP-2125A						
	MSP-2210A						
	MSP-2230A						
	MSP-2235A						
	MSP-4105A						
	MSP-4210A						
	MSP-4230A						
	MSP-4235A						
	MSP-6210A						
	MSP-6230A						
	MSP-6235A						
	MSP-6220B						
<b>TNMG 160404-SM3</b> <b>TNMG 160408-SM3</b> <b>TNMG 160412-SM3</b>	MSC-4115A						
	MSC-4125A						
	MSC-4130A						
	MSK-3110A						
	MSK-3125B						
	MSP-1210A						
	MSP-1225A	●	○	●			
	MSP-1235A						
	MSP-2125A	●	●			●	
	MSP-2210A						
	MSP-2230A		●			●	
	MSP-2235A						
	MSP-4105A	●	●			●	
	MSP-4210A						
	MSP-4230A	●	○	●			
	MSP-4235A						
	MSP-6210A						
	MSP-6230A		●			●	
	MSP-6235A						
	MSP-6220B						

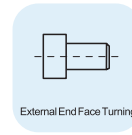

● Recommended ○ Good

## TNMA/TNMG



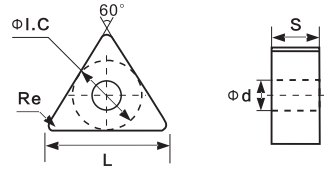

	IC [mm]	D1 [mm]	L [mm]	S [mm]
16	9.525	3.81	16.50	4.76



Type	Grade	P	M	K	N	S	H
<b>TNMG 160404-TM</b>	MSC-4115A						
<b>TNMG 160408-TM</b>	MSC-4125A	●	●				
<b>TNMG 160412-TM</b>	MSC-4130A	●					
	MSK-3110A						
	MSK-3125B						
	MSP-1210A						
	MSP-1225A						
	MSP-1235A						
	MSP-2125A						
	MSP-2210A						
	MSP-2230A						
	MSP-2235A						
	MSP-4105A						
	MSP-4210A						
	MSP-4230A						
	MSP-4235A						
	MSP-6210A						
	MSP-6230A						
	MSP-6235A						
MSP-6220B							
<b>TNMG 160408-KH</b>	MSC-4115A						
<b>TNMG 160412-KH</b>	MSC-4125A						
	MSC-4130A						
	MSK-3110A						
	MSK-3125B			●			
	MSP-1210A						
	MSP-1225A						
	MSP-1235A						
	MSP-2125A						
	MSP-2210A						
	MSP-2230A						
	MSP-2235A						
	MSP-4105A						
	MSP-4210A						
	MSP-4230A						
	MSP-4235A						
	MSP-6210A						
	MSP-6230A						
	MSP-6235A						
MSP-6220B							

● Recommended ○ Good

Type	Grade	P	M	K	N	S	H
<b>TNMG 160404-CF2</b>	MS-TC30B	●	○	●			
<b>TNMG 160408-CF2</b>							
							
	<b>TNMG 160404-UF1</b>	MS-TC30B	●	○	●		
<b>TNMG 160408-UF1</b>							
							

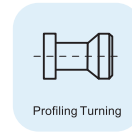

● Recommended ○ Good

## VNMG



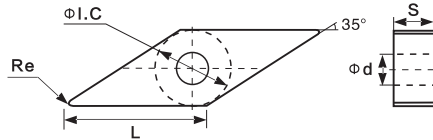

1604	IC [mm]	D1 [mm]	L [mm]	S [mm]
1604	9.525	3.81	16.60	4.76



Type	Grade	P	M	K	N	S	H
	VNMG 160404-MM MSC-4115A						
	MSC-4125A						
	MSC-4130A						
	MSK-3110A						
	MSK-3125B						
	MSP-1210A						
	MSP-1225A						
	MSP-1235A						
	MSP-2125A	●	●				●
	MSP-2210A						
	MSP-2230A						
	MSP-2235A						
	MSP-4105A						
	MSP-4210A						
	MSP-4230A						
	MSP-4235A						
	MSP-6210A						
	MSP-6230A						
	MSP-6235A						
MSP-6220B							
	VNMG 160408-MR MSC-4115A						
	MSC-4125A						
	MSC-4130A						
	MSK-3110A						
	MSK-3125B						
	MSP-1210A						
	MSP-1225A	●	○	●			
	MSP-1235A						
	MSP-2125A	●	●				●
	MSP-2210A						
	MSP-2230A		●				●
	MSP-2235A						
	MSP-4105A	●	●				●
	MSP-4210A						
	MSP-4230A	●	○	●			
	MSP-4235A						
	MSP-6210A						
	MSP-6230A						
	MSP-6235A						
MSP-6220B							

● Recommended ○ Good

Type	Grade	P	M	K	N	S	H
	VNMG 160404-PM4 MSC-4115A						
	VNMG 160408-PM4 MSC-4125A						
	MSC-4130A	●					
	MSK-3110A						
	MSK-3125B						
	MSP-1210A						
	MSP-1225A	●	●	●			
	MSP-1235A						
	MSP-2125A						
	MSP-2210A						
	MSP-2230A		●				●
	MSP-2235A						
	MSP-4105A						
	MSP-4210A						
	MSP-4230A	●	●	●			
	MSP-4235A						
	MSP-6210A						
	MSP-6230A						
	MSP-6235A						
MSP-6220B							
	VNMG 160404-SM3 MSC-4115A						
	VNMG 160408-SM3 MSC-4125A						
	MSC-4130A						
	MSK-3110A						
	MSK-3125B						
	MSP-1210A						
	MSP-1225A	●	○	●			
	MSP-1235A						
	MSP-2125A	●	●				●
	MSP-2210A						
	MSP-2230A		●				●
	MSP-2235A						
	MSP-4105A	●	●				●
	MSP-4210A						
	MSP-4230A	●	○	●			
	MSP-4235A						
	MSP-6210A						
	MSP-6230A						
	MSP-6235A						
MSP-6220B							

● Recommended ○ Good

## VNMG

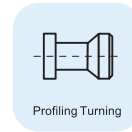

	IC [mm]	D1 [mm]	L [mm]	S [mm]
1604	9.525	3.81	16.60	4.76

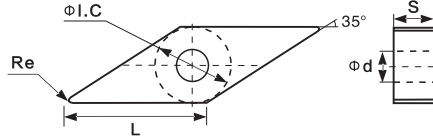



Type	Grade	P	M	K	N	S	H
VNMG 160404-TM	MSC-4115A						
VNMG 160408-TM	MSC-4125A	●	●				
	MSC-4130A						
	MSK-3110A						
	MSK-3125B						
	MSP-1210A						
	MSP-1225A						
	MSP-1235A						
	MSP-2125A						
	MSP-2210A						
	MSP-2230A						
	MSP-2235A						
	MSP-4105A						
	MSP-4210A						
	MSP-4230A						
	MSP-4235A						
	MSP-6210A						
	MSP-6230A						
	MSP-6235A						
	MSP-6220B						

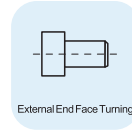

● Recommended ○ Good

## WNMA/WNMG



	IC [mm]	D1 [mm]	L [mm]	S [mm]
0804	12.700	5.16	8.70	4.76

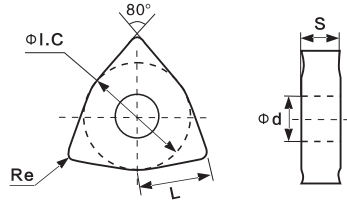

Type	Grade	P	M	K	N	S	H
<b>WNMA 080408</b> <b>WNMA 080412</b>	MSC-4115A						
	MSC-4125A						
	MSC-4130A						
	MSK-3110A			●			
	MSK-3125B						
	MSP-1210A						
	MSP-1225A						
	MSP-1235A						
	MSP-2125A						
	MSP-2210A						
	MSP-2230A						
	MSP-2235A						
	MSP-4105A						
	MSP-4210A						
	MSP-4230A						
	MSP-4235A						
	MSP-6210A						
	MSP-6230A						
	MSP-6235A						
	MSP-6220B						
<b>WNMG 080408-KR5</b> <b>WNMG 080412-KR5</b>	MSC-4115A						
	MSC-4125A						
	MSC-4130A						
	MSK-3110A			●			
	MSK-3125B			●			
	MSP-1210A						
	MSP-1225A	●	○	●			
	MSP-1235A	●	○	●			
	MSP-2125A						
	MSP-2210A						
	MSP-2230A		●			●	
	MSP-2235A						
	MSP-4105A						
	MSP-4210A						
	MSP-4230A	●	○	●			
	MSP-4235A	●	○	●			
	MSP-6210A						
	MSP-6230A		●			●	
	MSP-6235A						
	MSP-6220B						

● Recommended ○ Good

Type	Grade	P	M	K	N	S	H
<b>WNMG 080404-MM</b> <b>WNMG 080408-MM</b>	MSC-4115A						
	MSC-4125A						
	MSC-4130A						
	MSK-3110A						
	MSK-3125B						
	MSP-1210A						
	MSP-1225A	●	○	●			
	MSP-1235A						
	MSP-2125A	●	●			●	
	MSP-2210A						
	MSP-2230A		●			●	
	MSP-2235A						
	MSP-4105A						
	MSP-4210A						
	MSP-4230A	●	○	●			
	MSP-4235A						
	MSP-6210A						
	MSP-6230A		●			●	
	MSP-6235A						
	MSP-6220B						
<b>WNMG 080408-MR</b> <b>WNMG 080412-MR</b>	MSC-4115A						
	MSC-4125A						
	MSC-4130A						
	MSK-3110A						
	MSK-3125B						
	MSP-1210A						
	MSP-1225A	●	○	●			
	MSP-1235A						
	MSP-2125A	●	●			●	
	MSP-2210A						
	MSP-2230A		●			●	
	MSP-2235A						
	MSP-4105A						
	MSP-4210A						
	MSP-4230A	●	○	●			
	MSP-4235A						
	MSP-6210A						
	MSP-6230A						
	MSP-6235A						
	MSP-6220B						

● Recommended ○ Good

## WNMA/WNMG

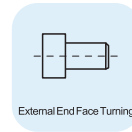

W	IC [mm]	D1 [mm]	L [mm]	S [mm]
0804	12.700	5.16	8.70	4.76

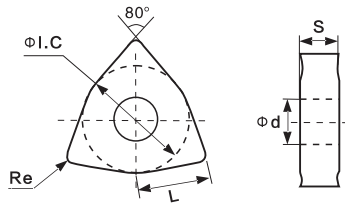

Type	Grade	P	M	K	N	S	H
<b>WNMG 080408-NM</b> <b>WNMG 080412-NM</b>	MSC-4115A						
	MSC-4125A						
	MSC-4130A	●					
	MSK-3110A						
	MSK-3125B						
	MSP-1210A						
	MSP-1225A						
	MSP-1235A						
	MSP-2125A						
	MSP-2210A						
	MSP-2230A						
	MSP-2235A						
	MSP-4105A						
	MSP-4210A						
	MSP-4230A						
	MSP-4235A						
	MSP-6210A						
	MSP-6230A						
MSP-6235A							
MSP-6220B							
<b>WNMG 080404-PM4</b> <b>WNMG 080408-PM4</b> <b>WNMG 080412-PM4</b>	MSC-4115A						
	MSC-4125A						
	MSC-4130A	●					
	MSK-3110A						
	MSK-3125B						
	MSP-1210A						
	MSP-1225A	●	○	●			
	MSP-1235A						
	MSP-2125A						
	MSP-2210A						
	MSP-2230A		●			●	
	MSP-2235A						
	MSP-4105A						
	MSP-4210A						
	MSP-4230A	●	○	●			
	MSP-4235A						
	MSP-6210A						
	MSP-6230A						
MSP-6235A							
MSP-6220B							

● Recommended ○ Good

Type	Grade	P	M	K	N	S	H
<b>WNMG 080404-SM3</b> <b>WNMG 080408-SM3</b>	MSC-4115A						
	MSC-4125A						
	MSC-4130A						
	MSK-3110A						
	MSK-3125B						
	MSP-1210A						
	MSP-1225A	●	○	●			
	MSP-1235A						
	MSP-2125A	●	●			●	
	MSP-2210A		●			●	
	MSP-2230A		●			●	
	MSP-2235A						
	MSP-4105A						
	MSP-4210A	●	○	●			
	MSP-4230A	●	○	●			
	MSP-4235A						
	MSP-6210A						
	MSP-6230A						
MSP-6235A							
MSP-6220B							
<b>WNMG 080404-TM</b> <b>WNMG 080408-TM</b> <b>WNMG 080412-TM</b>	MSC-4115A						
	MSC-4125A	●	●				
	MSC-4130A						
	MSK-3110A						
	MSK-3125B						
	MSP-1210A						
	MSP-1225A						
	MSP-1235A						
	MSP-2125A						
	MSP-2210A						
	MSP-2230A						
	MSP-2235A						
	MSP-4105A						
	MSP-4210A						
	MSP-4230A						
	MSP-4235A						
	MSP-6210A						
	MSP-6230A						
MSP-6235A							
MSP-6220B							

● Recommended ○ Good

## WNMA/WNMG

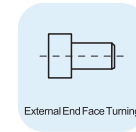

	IC [mm]	D1 [mm]	L [mm]	S [mm]
0804	12.700	5.16	8.70	4.76

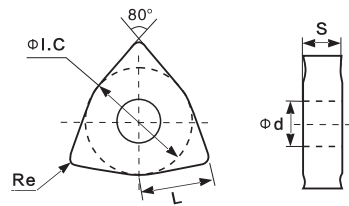

Type	Grade	P	M	K	N	S	H
WNMG 080408-KH	MSC-4115A						
	WNMG 080412-KH						
	MSC-4125A						
	MSC-4130A						
	MSK-3110A						
	MSK-3125B			●			
	MSP-1210A						
	MSP-1225A						
	MSP-1235A						
	MSP-2125A						
	MSP-2210A						
	MSP-2230A						
	MSP-2235A						
	MSP-4105A						
	MSP-4210A						
	MSP-4230A						
	MSP-4235A						
	MSP-6210A						
	MSP-6230A						
	MSP-6235A						
MSP-6220B							



● Recommended ○ Good



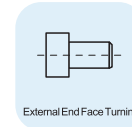
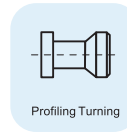
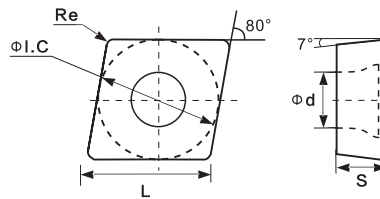

## CCMT/CCGT

	IC [mm]	D1 [mm]	L [mm]	S [mm]
0602	6.350	2.80	6.40	2.38
09T3	9.525	4.40	9.70	3.97
1204	12.700	5.50	12.90	4.76



Type	Grade	P	M	K	N	S	H
<b>CCMT 060204-PF</b> 	MSC-4115A						
	MSC-4125A						
	MSC-4130A						
	MSK-3110A						
	MSK-3125B			●			
	MSP-1210A						
	MSP-1225A						
	MSP-1235A						
	MSP-2125A						
	MSP-2210A		●			●	
	MSP-2230A	●	●				●
	MSP-2235A						
	MSP-4105A						
	MSP-4210A						
	MSP-4230A						
	MSP-4235A						
	MSP-6210A						
	MSP-6230A						
	MSP-6235A						
	MSP-6220B						
<b>CCMT 060204-PM4</b> <b>CCMT 060208-PM4</b> <b>CCMT 09T308-PM4</b> 	MSC-4115A						
	MSC-4125A						
	MSC-4130A	●					
	MSK-3110A						
	MSK-3125B						
	MSP-1210A						
	MSP-1225A	●	●			●	
	MSP-1235A						
	MSP-2125A	●	●			●	
	MSP-2210A						
	MSP-2230A		●			●	
	MSP-2235A						
	MSP-4105A						
	MSP-4210A						
	MSP-4230A	●	○	●			
	MSP-4235A						
	MSP-6210A						
	MSP-6230A		●			●	
	MSP-6235A						
	MSP-6220B						

● Recommended ○ Good



Type	Grade	P	M	K	N	S	H
<b>CCMT 060204-SM3</b> <b>CCMT 060208-SM3</b> <b>CCMT 09T304-SM3</b> <b>CCMT 09T308-SM3</b> <b>CCMT 120404-SM3</b> <b>CCMT 120408-SM3</b> 	MSC-4115A						
	MSC-4125A						
	MSC-4130A						
	MSK-3110A						
	MSK-3125B						
	MSP-1210A						
	MSP-1225A	●	○	●			
	MSP-1235A						
	MSP-2125A	●	●			●	
	MSP-2210A		●			●	
	MSP-2230A		●			●	
	MSP-2235A						
	MSP-4105A						
	MSP-4210A	●	○	●			
	MSP-4230A	●	○	●			
	MSP-4235A						
	MSP-6210A						
	MSP-6230A		●			●	
	MSP-6235A						
	MSP-6220B						
<b>CCGT 060201-SL</b> <b>CCGT 060202-SL</b> <b>CCGT 09T301-SL</b> <b>CCGT 09T302-SL</b> 	MSC-4115A						
	MSC-4125A						
	MSC-4130A						
	MSK-3110A						
	MSK-3125B						
	MSP-1210A						
	MSP-1225A						
	MSP-1235A						
	MSP-2125A						
	MSP-2210A						
	MSP-2230A						
	MSP-2235A						

● Recommended ○ Good

## CCMT/CCGT

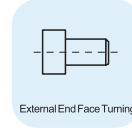
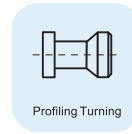
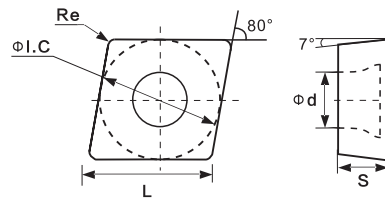
	IC [mm]	D1 [mm]	L [mm]	S [mm]
0602	6.350	2.80	6.40	2.38
09T3	9.525	4.40	9.70	3.97
1204	12.700	5.50	12.90	4.76



Type	Grade	P	M	K	N	S	H
<b>CCMT 060204-CF2</b> <b>CCMT 09T304-CF2</b> <b>CCMT 09T308-CF2</b> 	MS-TC30B	●	○	●			
<b>CCMT 060204-UF1</b> <b>CCMT 060208-UF1</b> <b>CCMT 09T304-UF1</b> <b>CCMT 09T308-UF1</b> 	MS-TC30B	●	●	○			

● Recommended ○ Good

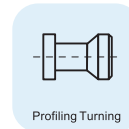

## DCMT/DCGT

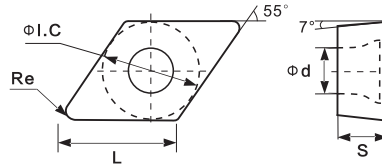

$\frac{D}{S}$	IC [mm]	D1 [mm]	L [mm]	S [mm]
0702	6.350	2.80	7.80	2.38
11T3	9.525	4.40	11.60	3.97

Type	Grade	P	M	K	N	S	H
<b>DCMT 070204-PF</b> <b>DCMT 11T308-PF</b>	MSC-4115A						
	MSC-4125A						
	MSC-4130A						
	MSK-3110A						
	MSK-3125B						
	MSP-1210A						
	MSP-1225A						
	MSP-1235A						
	MSP-2125A						
	MSP-2210A						
	MSP-2230A						
	MSP-2235A						
	MSP-4105A	●	●				●
	MSP-4210A						
	MSP-4230A						
	MSP-4235A						
	MSP-6210A						
	MSP-6230A		●				●
	MSP-6235A						
	MSP-6220B						
<b>DCMT 070208-PM4</b> <b>DCMT 11T308-PM4</b>	MSC-4115A						
	MSC-4125A						
	MSC-4130A	●					
	MSK-3110A						
	MSK-3125B						
	MSP-1210A						
	MSP-1225A	●	●	●			
	MSP-1235A						
	MSP-2125A						
	MSP-2210A						
	MSP-2230A		●				●
	MSP-2235A						
	MSP-4105A						
	MSP-4210A						
	MSP-4230A	●	○	●			
	MSP-4235A						
MSP-6210A							
MSP-6230A							
MSP-6235A							
MSP-6220B							

● Recommended ○ Good

Type	Grade	P	M	K	N	S	H
<b>DCMT 070204-SM3</b> <b>DCMT 070208-SM3</b> <b>DCMT 11T304-SM3</b> <b>DCMT 11T308-SM3</b>	MSC-4115A						
	MSC-4125A						
	MSC-4130A						
	MSK-3110A						
	MSK-3125B						
	MSP-1210A						
	MSP-1225A	●	○	●			
	MSP-1235A						
	MSP-2125A	●	●				●
	MSP-2210A		●				●
	MSP-2230A		●				●
	MSP-2235A						
	MSP-4105A						
	MSP-4210A	●	○	●			
	MSP-4230A	●	○	●			
	MSP-4235A						
	MSP-6210A						
	MSP-6230A		●				●
	MSP-6235A						
	MSP-6220B						
<b>DCMT 070204-SP</b> <b>DCMT 070208-SP</b>	MSC-4115A						
	MSC-4125A	●					
	MSC-4130A						
	MSK-3110A						
	MSK-3125B						
	MSP-1210A	●	●	●			
	MSP-1225A						
	MSP-1235A						
	MSP-2125A						
	MSP-2210A						
	MSP-2230A		●				●
	MSP-2235A						
	MSP-4105A						
	MSP-4210A						
	MSP-4230A	●	○	●			
	MSP-4235A						
MSP-6210A							
MSP-6230A		●				●	
MSP-6235A							
MSP-6220B							

● Recommended ○ Good

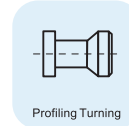

## DCMT/DCGT

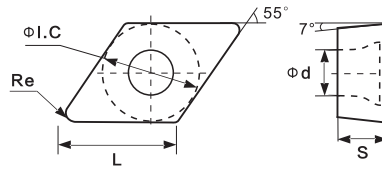

	IC [mm]	D1 [mm]	L [mm]	S [mm]
0702	6.350	2.80	7.80	2.38
11T3	9.525	4.40	11.60	3.97

Type	Grade	P	M	K	N	S	H
<b>DCGT 070201-SL</b>	MSC-4115A						
<b>DCGT 070202-SL</b>	MSC-4125A						
<b>DCGT 11T301-SL</b>	MSC-4130A						
<b>DCGT 11T302-SL</b>	MSK-3110A						
	MSK-3125B						
	MSP-1210A						
	MSP-1225A						
	MSP-1235A						
	MSP-2125A						
	MSP-2210A						
	MSP-2230A						
	MSP-2235A						
	MSP-4105A						
	MSP-4210A						
	MSP-4230A						
	MSP-4235A						
	MSP-6210A						
	MSP-6230A						
	MSP-6235A						
	MSP-6220B		●			●	



● Recommended ○ Good

## SCMT

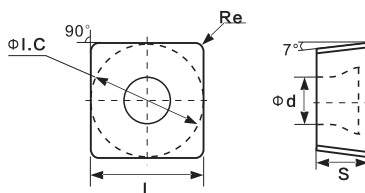
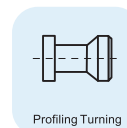

s	IC [mm]	D1 [mm]	L [mm]	S [mm]
1204	12.700	5.50	12.70	4.76

Type	Grade	P	M	K	N	S	H
 SCMT 120404-SM3 SCMT 120408-SM3	MSC-4115A						
	MSC-4125A						
	MSC-4130A						
	MSK-3110A						
	MSK-3125B						
	MSP-1210A						
	MSP-1225A	●	○	●			
	MSP-1235A						
	MSP-2125A	●	●			●	
	MSP-2210A		●			●	
	MSP-2230A		●			●	
	MSP-2235A						
	MSP-4105A	●	○	●			
	MSP-4210A						
	MSP-4230A	●	○	●			
	MSP-4235A						
	MSP-6210A						
	MSP-6230A		●			●	
	MSP-6235A						
	MSP-6220B						

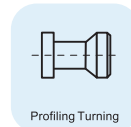

● Recommended ○ Good



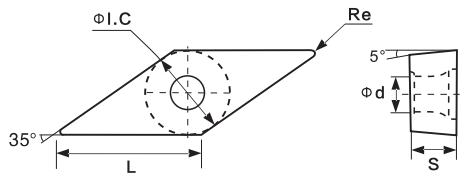

## VBMT/VCMT/VBGT

	IC [mm]	D1 [mm]	L [mm]	S [mm]
1103	6.350	2.80	11.10	3.18
1604	9.525	4.40	16.60	4.76



Type	Grade	P	M	K	N	S	H
<b>VBMT 160404-MF</b> <b>VBMT 160408-MF</b> 	MSC-4115A						
	MSC-4125A						
	MSC-4130A						
	MSK-3110A						
	MSK-3125B						
	MSP-1210A						
	MSP-1225A	●	○	●			
	MSP-1235A						
	MSP-2125A	●	●			●	
	MSP-2210A		●			●	
	MSP-2230A		●			●	
	MSP-2235A						
	MSP-4105A						
	MSP-4210A						
	MSP-4230A	●	○	●			
	MSP-4235A						
	MSP-6210A						
	MSP-6230A		●			●	
	MSP-6235A						
	MSP-6220B						
<b>VBMT 160404-PM4</b> <b>VBMT 160408-PM4</b> 	MSC-4115A						
	MSC-4125A						
	MSC-4130A						
	MSK-3110A						
	MSK-3125B						
	MSP-1210A						
	MSP-1225A	●	●			●	
	MSP-1235A						
	MSP-2125A						
	MSP-2210A						
	MSP-2230A		●			●	
	MSP-2235A						
	MSP-4105A						
	MSP-4210A						
	MSP-4230A	●	○	●			
	MSP-4235A						
	MSP-6210A						
	MSP-6230A						
	MSP-6235A						
	MSP-6220B						

● Recommended ○ Good

Type	Grade	P	M	K	N	S	H
<b>VBMT 110304-SM3</b> <b>VBMT 110308-SM3</b> <b>VBMT 160404-SM3</b> <b>VBMT 160408-SM3</b> 	MSC-4115A						
	MSC-4125A						
	MSC-4130A						
	MSK-3110A						
	MSK-3125B						
	MSP-1210A	●	○	●			
	MSP-1225A						
	MSP-1235A						
	MSP-2125A	●	●			●	
	MSP-2210A		●			●	
	MSP-2230A		●			●	
	MSP-2235A						
	MSP-4105A						
	MSP-4210A	●	○	●			
	MSP-4230A	●	○	●			
	MSP-4235A						
	MSP-6210A						
	MSP-6230A		●			●	
	MSP-6235A						
	MSP-6220B						
<b>VBMT 110304-SP</b> <b>VBMT 110308-SP</b> <b>VBMT 160404-SP</b> <b>VBMT 160408-SP</b> 	MSC-4115A						
	MSC-4125A	●	●				
	MSC-4130A						
	MSK-3110A						
	MSK-3125B						
	MSP-1210A						
	MSP-1225A	●	●	●			
	MSP-1235A						
	MSP-2125A						
	MSP-2210A						
	MSP-2230A		●			●	
	MSP-2235A						
	MSP-4105A						
	MSP-4210A						
	MSP-4230A	●	○	●			
	MSP-4235A						
	MSP-6210A						
	MSP-6230A						
	MSP-6235A						
	MSP-6220B						

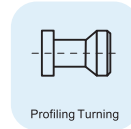

● Recommended ○ Good

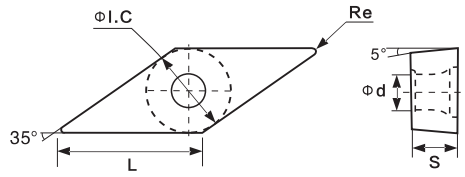

## VBMT/VCMT/VBGT

	IC [mm]	D1 [mm]	L [mm]	S [mm]
1103	6.350	2.80	11.10	3.18
1604	9.525	4.40	16.60	4.76

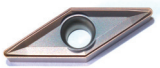

Type	Grade	P	M	K	N	S	H
	VCMT 160404-SM3 MSC-4115A						
	VCMT 160408-SM3 MSC-4125A						
	MSC-4130A						
	MSK-3110A						
	MSK-3125B						
	MSP-1210A						
	MSP-1225A	●	○	●			
	MSP-1235A						
	MSP-2125A	●	●			●	
	MSP-2210A						
	MSP-2230A		●			●	
	MSP-2235A						
	MSP-4105A						
	MSP-4210A						
	MSP-4230A	●	○	●			
	MSP-4235A						
	MSP-6210A						
	MSP-6230A		●			●	
	MSP-6235A						
	MSP-6220B						
	VBGT 160401-SM MSC-4115A						
	VBGT 160402-SM MSC-4125A						
	MSC-4130A						
	MSK-3110A						
	MSK-3125B						
	MSP-1210A						
	MSP-1225A						
	MSP-1235A						
	MSP-2125A						
	MSP-2210A						
	MSP-2230A						
	MSP-2235A						
	MSP-4105A						
	MSP-4210A						
	MSP-4230A						
	MSP-4235A						
	MSP-6210A						
	MSP-6230A						
	MSP-6235A						
	MSP-6220B		●			●	

● Recommended ○ Good

Type	Grade	P	M	K	N	S	H
	VCGT 160401-SM MSC-4115A						
	VCGT 160402-SM MSC-4125A						
	MSC-4130A						
	MSK-3110A						
	MSK-3125B						
	MSP-1210A						
	MSP-1225A						
	MSP-1235A						
	MSP-2125A						
	MSP-2210A						
	MSP-2230A						
	MSP-2235A						
	MSP-4105A						
	MSP-4210A						
	MSP-4230A						
	MSP-4235A						
	MSP-6210A						
	MSP-6230A						
	MSP-6235A						
	MSP-6220B		●				●

● Recommended ○ Good

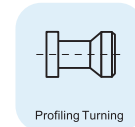

## TCMT

	IC [mm]	D1 [mm]	L [mm]	S [mm]
0902	5.560	2.50	9.60	2.38
1102	6.350	2.80	11.00	2.38
16T3	9.525	4.40	16.50	3.97

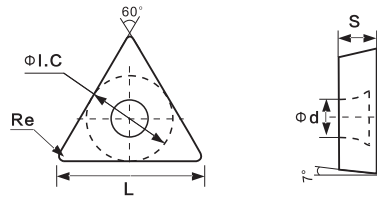

Type	Grade	P	M	K	N	S	H
<b>TCMT 16T308-PM4</b>	MSC-4115A						
<b>TCMT 110204-PM4</b>	MSC-4125A						
<b>TCMT 110208-PM4</b>	MSC-4130A	●					
	MSK-3110A						
	MSK-3125B						
	MSP-1210A						
	MSP-1225A	●	●	●			
	MSP-1235A						
	MSP-2125A						
	MSP-2210A						
	MSP-2230A		●			●	
	MSP-2235A						
	MSP-4105A						
	MSP-4210A						
	MSP-4230A	●	○	●			
	MSP-4235A						
	MSP-6210A						
	MSP-6230A						
	MSP-6235A						
	MSP-6220B						
<b>TCMT 16T308-SM3</b>	MSC-4115A						
<b>TCMT 110204-SM3</b>	MSC-4125A						
<b>TCMT 110208-SM3</b>	MSC-4130A						
	MSK-3110A						
	MSK-3125B						
	MSP-1210A						
	MSP-1225A	●	○	●			
	MSP-1235A						
	MSP-2125A	●	●			●	
	MSP-2210A		●			●	
	MSP-2230A		●			●	
	MSP-2235A						
	MSP-4105A						
	MSP-4210A	●	○	●			
	MSP-4230A	●	○	●			
	MSP-4235A						
	MSP-6210A						
	MSP-6230A		●			●	
	MSP-6235A						
	MSP-6220B						

● Recommended ○ Good

Type	Grade	P	M	K	N	S	H
<b>TCMT 110204-CF2</b>	MS-TC30B	●	○	●			
<b>TCMT 090204-UF1</b>	MS-TC30B	●	○	●			
	<b>TCMT 110204-UF1</b>						

● Recommended ○ Good





**PARTING &  
GROOVING  
INSERTS**

# PARTING / GROOVING INSERTS

## Characteristics of Chip-breakers

**G** Type: Specially designed chip breaker allows narrow chips to promote better flow  
Specifically designed for grooving applications

- For carbon steel, alloy steel and cast iron



**M** Type: Specially designed chip breaker allows narrow chips to promote better flow  
Specifically designed for groove-turn

- For carbon steel, alloy steel and cast iron



**TC** Type: Sharp cutting edge, low cutting resistance  
Specifically designed for parting, grooving

- For carbon steel, alloy steel



**J** Type: 1st choice for soft materials in parting and deep grooving

- Sharp cutting edge & low cutting force
- Low-to-medium feed
- Tubes, small diameter and thin-wall parts
- For stainless steel & low carbon steel



**T** Type: 1st choice for side turning of cast iron

- Turning and grooving with various geometry
- Steel and cast iron



**C** Type: 1st choice for general use in parting and deep grooving

- Stable cutting edge & interrupted cut
- Medium-to-high feed
- For carbon steel, alloy steel and cast iron







**X** Type: 1st choice for general use in groove-turn

- Multi functional chip breaker for external, internal and face machining
- Low cutting force and good chip control
- Medium-to-high feed grooving, low-to-medium feed turning

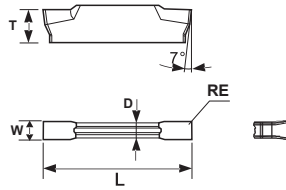

## MSMN/MSJN





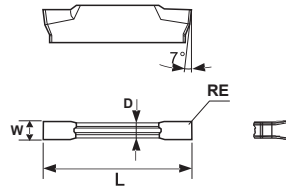

Insert Shape	Type	Dimension(mm)					P		M		K	
		W	RE	L	D	T	MSC-7125A	MSP-7125A	MSC-7125A	MSP-7125A	MSC-7125A	MSP-7125A
	MSMN150-G	1.50	0.15	16.0	1.20	3.50	●		●		●	
	MSMN200-G	2.00	0.20	16.0	1.60	3.50	●		●		●	
	MSMN250-G	2.50	0.20	18.5	2.00	3.85	●		●		●	
	MSMN300-M	3.00	0.40	21.0	2.35	4.80	●		●		●	
	MSMN400-M	4.00	0.40	21.0	3.30	4.80	●		●		●	
	MSMN500-M	5.00	0.80	26.0	4.10	5.80	●		●		●	
	MSMN600-M	6.00	0.80	26.0	5.00	5.80	●		●		●	
	MSJN150-TC	1.50	0.15	16.0	1.20	3.50		●		●		●
	MSJN200-TC	2.00	0.20	16.0	1.60	3.50		●		●		●
	MSJN250-TC	2.50	0.20	18.5	2.00	3.85		●		●		●
	MSJN300-TC	3.00	0.40	21.0	2.35	4.80		●		●		●
	MSJN400-TC	4.00	0.40	21.0	3.30	4.80		●		●		●
	MSJN500-TC	5.00	0.80	26.0	4.10	5.80		●		●		●

● Recommended ○ Good

## MSTG



Insert Shape	Type	Dimension(mm)					P		M		K	
		W	RE	L	D	T	MSP-7125B	MSP-8125B	MSP-7125B	MSP-8125B	MSP-7125B	MSP-8125B
	MSTG2-J	2.0	0.20	20	1.7	-	○	●	○	●	●	○
	MSTG3-J	3.0	0.20	20	2.4	-	○	●	○	●	●	○
	MSTG4-J	4.0	0.40	20	3.0	-	○	●	○	●	●	○
	MSTG2-C	2.0	0.2	20	1.7	-	○	●	○	●	●	○
	MSTG3-C	3.0	0.2	20	2.4	-	○	●	○	●	●	○
	MSTG4-C	4.0	0.3	20	3.0	-	○	●	○	●	●	○
	MSTG3-T	3.0	0.4	20	2.2	-	○	●	○	●	●	○
	MSTG4-T	4.0	0.4	20	3.0	-	○	●	○	●	●	○
	MSTG3-X	3.0	0.3	20	3.0	-	○	●	○	●	●	○
	MSTG4-X	4.0	0.4	20	4.0	-	○	●	○	●	●	○

● Recommended ○ Good



### Carbide Tool Reconditioning

*Our contribution for sustainable living in partnership with our customers*

*We enable our customers to support their environmental programs*



### Carbide Recycling

“Preserve, Protect, and Nurture Nature!”

## For Further Enquiries

**M.S. Tools & Manufacturing Company Pvt. Ltd.**

**Manufacturing Facility:**

Chennai, Bengaluru

**Sales:**

PAN India



Manufacturing  
Sales

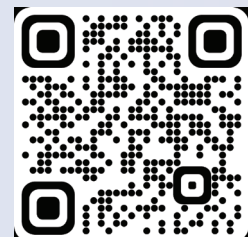

scan the QR for more info..

+91 93448 07872

info@mstm.co.in

www.mstm.co.in